

CPT-DFC2

**DF Series Communications Peripheral Card
Technical Brief**

August 2016
Manual Release 1
Card Revision 1

Copyright © 2016

Creative Power Technologies P/L
P.O. Box 714
MULGRAVE
Victoria, 3170

**CREATIVE POWER
TECHNOLOGIES**

Tel: +61-3-9543-8805
Fax: +61-3-9543-8802
Email: tech@creativepower.com.au

CPT-DFC2 Manual Revision History

CARD REVISION 1: Initial Board

Generated as a variation from the DFC1 with both USB Type B and Mini USB type B connectors.

No SPI interface

Release 1.0 – Initial Release

Table of Contents

1.0	DF Series Overview.....	1
1.1	DF Series Card Range	1
1.1.1	DF Series Control Card:	1
1.1.2	DF Series Peripheral Cards.....	2
1.1.2.1	CPT-DFC1.....	2
1.1.2.2	CPT-DFC2.....	2
1.1.2.3	CPT-DFC4.....	2
1.1.2.4	CPT-DFJ.....	2
1.1.3	DF Series Inverter Motherboard.....	3
1.1.3.1	CPT-DFM1.....	3
1.1.3.2	CPT-DFM2.....	4
1.2	DF Series Interfaces.....	4
1.2.1	Main Interface.....	4
1.2.2	Communications Interface.....	5
1.2.3	JTAG Interface	5
2.0	Overview of the CPT-DFC2.....	6
3.0	Specifications	3
3.1	Communications Interface.....	3
3.1.1	USB UART Interface	3
3.1.2	CAN Interface.....	3
3.2	General	4
3.3	Order Codes.....	4
	Appendices	5
	Appendix A Component Layout.....	6
	Appendix B Connector Pinouts	7
	Appendix C LEDs on CPT-DFC2	9
	Appendix D Texas Instruments Documentation.....	9

DF Series Concept

1.0 DF Series Overview

The DF Series provides a modular, flexible integrated inverter controller platform through a range of interconnected cards. This structure provides an overall reduction in the footprint of the inverter, as well as providing a level of flexibility to support inverters rated from 1kW to 100kW+.

The DF Series Control Card supports Texas Instruments PTP footprint based Piccolo and Delfino Microcontrollers (MCU). Creative Power is actively supporting a subset of these MCU variations as their feature sets are closely aligned. The latest range of MCUs support TI's new integrated analog and control peripherals that are designed to consolidate additional functionality within the MCU.

The modular nature of the DF Series system is seen through the flexible DF Series Interface which connects the DF Series Control Card to a wide range of peripheral cards. These cards include an Inverter Controller and various Communications Peripheral cards. Figure 1-1 shows the general structure of the DF Series stack, with the Control Card mounted to the Inverter Motherboard and one or more Communications Peripheral Cards mounted above.

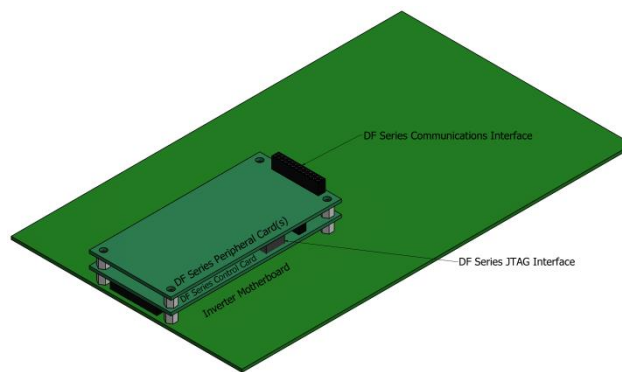

Figure 1-1: DF Series Card Stack Conceptual Overview

1.1 DF Series Card Range

The following is a list of the available cards within the DF Series. Additional cards will be added to the range as they become available.

1.1.1 DF Series Control Card:

The DF Series Control Card is available with the following part numbers:

- **CPT-DF28075 (TMS320F28075PTP MCU Processor)**
- CPT-DF28374S (TMS320F28374SPTP MCU Processor)
- CPT-DF28375S (TMS320F28375SPTP MCU Processor)
- CPT-DF28376S (TMS320F28376SPTP MCU Processor)
- **CPT-DF28377S (TMS320F28377SPTP MCU Processor)**
- CPT-DF28374D (TMS320F28374DPTP MCU Processor)
- CPT-DF28375D (TMS320F28375DPTP MCU Processor)
- CPT-DF28376D (TMS320F28376DPTP MCU Processor)
- **CPT-DF28377D (TMS320F28377DPTP MCU Processor)**

The part number corresponding to the DF Series Control Card must be specified as part of the order. The parts in bold are CPT standard load options.

The Control Card has a footprint of 96mm x 46mm (standard DF Series Footprint size)

CPT-DFC2 DF SERIES COMMUNICATIONS PERIPHERAL CARD TECHNICAL BRIEF

1.1.2 DF Series Peripheral Cards

The Peripheral Cards can be mounted within the DF Stack above the Control Card, with interconnection through either the DF Communications Interface or, for the CPT-DFJ, the DF JTAG interface.

All Peripheral Cards are the standard DF Series Footprint size of 96mm x 46mm.

1.1.2.1 CPT-DFC1

CPT-DFC1 Peripheral Card provides external communications interfaces for the Control Card. It interfaces to the Control Card via the 26 way DF Communications Interface.

The CPT-DFC1 Peripheral Card supports the following functionality:

- Dual SCI to Isolated USB 2.0 Interface (two serial ports within the one USB connection)
 - USB-A: On-Card DIP Switch Selectable between SCIA and SCIC
 - USB-B: On-Card DIP Switch Selectable between SCIB and SCID
- Isolated CAN Interface
 - On-Card DIP Switch Selectable between CANA and CANB
- Isolated SPI Interface (isoSPI configuration)
 - Direction Selection: On-Card DIP Switch Selectable between Master/Slave
 - Mode Selection: On-Card DIP Switch Selectable Phase and Offset – SPI Modes 0-3
- Real-Time Clock (I²C) with Supercapacitor backup

1.1.2.2 CPT-DFC2

CPT-DFC2 Peripheral Card provides external communications interfaces for the Control Card. It interfaces to the Control Card via the 26 way DF Communications Interface.

The CPT-DFC2 Peripheral Card supports the following functionality:

- Dual SCI to Isolated USB 2.0 Interface (two serial ports within the one mini-USB or USB Type A connection)
 - USB-A: On-Card DIP Switch Selectable between SCIA and SCIC
 - USB-B: On-Card DIP Switch Selectable between SCIB and SCID
- Isolated CAN Interface
 - On-Card DIP Switch Selectable between CANA and CANB
- Real-Time Clock (I²C) with Supercapacitor backup

1.1.2.3 CPT-DFC4

CPT-DFC4 Peripheral Card provides external communications interfaces for the Control Card. It interfaces to the Control Card via the 26 way DF Communications Interface.

The CPT-DFC4 Peripheral Card supports the following functionality:

- Isolated RS422/RS485 Interface
 - On-Card DIP Switch Selectable between SCIB and SCID
 - On-Card DIP Switch Selectable between RS422 and RS485 Mode
- Isolated CAN Interface
 - On-Card DIP Switch Selectable between CANA and CANB
- Isolated SPI Interface (isoSPI configuration)
 - Direction Selection: On-Card DIP Switch Selectable between Master/Slave
 - Mode Selection: On-Card DIP Switch Selectable Phase and Offset – SPI Modes 0-3

1.1.2.4 CPT-DFJ

- JTAG + SCI to Isolated USB 2.0 Interface
 - USB based UART Serial Port through MCU Port SCIA
 - USB JTAG Emulation interface for programming and debugging of the Control Card

1.1.3 DF Series Inverter Motherboard

The CPT-DFM1 and CPT-DFM2 are Creative Power's next generation high performance MCU based inverter controller motherboards. They have been designed to provide flexibility of connection, combined with a minimum footprint for applications requiring an integrated solution to control up to a four-phase leg VSI stack (DFM1) or eight-phase leg VSI stack (DFM2).

The Inverter Motherboard is compatible with the DF Series Control Cards, and the CPT-DFM1/Control Card Platform combination contains on-card all necessary functions for a complete standalone inverter control system.

1.1.3.1 CPT-DFM1

The CPT-DFM1 Inverter Motherboard supports up to 8 plug/solder-in gate driver modules, enabling the system to be scaled to an applications specific topology and power rating. This board is designed for power stages up to around 10kW as standard. Higher power operation requires discussion with CPT.

The card has the following features:

- DF Series Main Interface Connectors
- 11 off Conditioned Analog Inputs (Low voltage inputs):
 - 3 off differential AC voltage inputs, (Three-phase 4 wire input compatible)
 - 3 off differential AC/DC voltage inputs
 - 5 off current inputs (AC and DC compatible)
- Isolated Digital I/O
 - 2 off isolated digital inputs (Field supply)
 - 3 off MOSFET switch isolated outputs
 - 2 off relay output, c/o contact
- On-Card Status Indication
 - 1 off Power LED
 - 4 off indication LEDs
 - Each isolated Digital I/O has an on-card status LED
- 4 off DIP switches
- 8 off CPT-Gxx compatible gate driver interface.
 - 3.3V TTL ePWM compatible outputs
 - Driven by ePWM1x to ePWM4x via the DF Series Main Interface
 - 2 sets of 4 fault feedback interrupt
 - Supports CPT's range of CPT-Gxx gate driver boards
 - Switched Gate Driver Supplies to drive isolating transformers on CPT-Gxx gate driver boards
 - Gate Driver Reset signal
- Quadrature Position Encoder input with Index and Strobe
- Push button reset
- On-card logic level supply generation
- Power supply operation from input 24VDC

The CPT-DFM1 card measures 220mm x 130mm.

CPT-DFC2 DF SERIES COMMUNICATIONS PERIPHERAL CARD TECHNICAL BRIEF

1.1.3.2 CPT-DFM2

The CPT-DFM2 Inverter Motherboard supports up to 16 external gate driver signals, enabling the system to be scaled to an applications specific topology and power rating. This board is designed for higher power applications than the CPT-DFM1 and is designed to interface with off-card Gate Driver Modules such as the CPT-E02, which contains 3 SKYPER 32 PRO modules to drive a 3 phase VSI power stage.

The card has the following features:

- DF Series Main Interface Connectors
- 11 off Conditioned Analog Inputs (Low voltage inputs):
 - 3 off differential AC voltage inputs, (Three-phase 4 wire input compatible)
 - 3 off differential AC/DC voltage inputs
 - 5 off current inputs (AC and DC compatible)
- Isolated Digital I/O
 - 3 off isolated digital inputs (Field supply)
 - 3 off MOSFET switch isolated outputs
 - 2 off relay output, c/o contact
- On-Card Status Indication
 - 1 off Power LED
 - 4 off indication LEDs
 - Each isolated Digital I/O has an on-card status LED
- 4 off DIP switches
- 16 off TTL compatible gate driver interface.
 - 5V TTL ePWM compatible outputs
 - Driven by ePWM1x to ePWM8x via the DF Series Main Interface
 - 2 sets of 8 fault feedback interrupt
 - Gate Driver Reset signal
 - 2 output connectors
- Quadrature Position Encoder input with Index and Strobe
- Push button reset
- On-card logic level supply generation
- Power supply operation from input 24VDC

The CPT-DFM2 card measures 220mm x 100mm.

1.2 DF Series Interfaces

The DF Series is modular in construction, which implies that signals require connection between the various cards. This is achieved using 2mm Dual-inline connectors between the cards within the DF Series Stack.

The Control Card consists of three Interface types:

- DF Series Main Interface (2 x 26-way + 3 x 20-way 2mm Dual-inline connectors)
- DF Series Communications Interface (26-way 2mm Dual-inline connector)
- DF Series JTAG Interface (10-way 2mm Dual-inline connector)

1.2.1 Main Interface

The DF Series Main Interface provides signal connection between the Control Card and Inverter Motherboard (CPT-DFM1). It is located on the underside of the Control Card.

The DF Series Main Interface has been broken up into 5 separate connectors. The Analog connector is located along the left hand edge of the Control Card and Motherboard. The remaining 4 connectors contain digital signals between the Control Card to the Motherboard. Their precise functionality must be specified within the user software to suit the Motherboard.

The Inverter Motherboard is configured as the base of the Main Interface Stack. The Control Card is mounted above the Inverter Motherboard.

CPT-DFC2 DF SERIES COMMUNICATIONS PERIPHERAL CARD TECHNICAL BRIEF

1.2.2 *Communications Interface*

The DF Series Communications Interface provides signal connection between the Control Card and DFC Series Peripheral Cards. The Communications Interface is located along the right hand edge of the DF Series Footprint cards.

The Control Card is configured as the base of the Communications Interface stack. All Peripherals cards are mounted above the Control Card.

1.2.3 *JTAG Interface*

The DF Series Control Card has a 10 way connector that interfaces to the isolated CPT-DFJ JTAG and SCI USB card.

The isolated JTAG and SCI board is compatible with TI's default JTAG software EEPROM specification and provides a fully isolated USB JTAG Interface with a Serial Communications Interface to SCIA on the MCU.

CPT-DFC2 Communications Peripheral Card

2.0 Overview of the CPT-DFC2

The CPT-DFC2 is a communications peripheral card that forms part of the DF Series Range. It contains a DF Series Communications Interface and supports isolated USB UARTs, CAN and SPI external interfaces as well as an on-card I²C real-time Clock (RTC).

The CPT-DFC2 card measures 96mm x 46mm and is consistent with the DF Series Interface structure.

On-card facilities include:

The CPT-DFC2 Peripheral Card has the following functionality

- Dual SCI to Isolated single Mini-USB Type B or USB Type B Interface
 - Two serial ports within the one USB connection
 - USB 2.0 Compliant
 - USB-A: On-Card DIP Switch Selectable between SCIA and SCIC
 - USB-B: On-Card DIP Switch Selectable between SCIB and SCID
 - ESD Signal Protection
- Isolated CAN Interface
 - Option of Mini-USB CAN connector or PTSM 2mm Header style
 - On-Card DIP Switch Selectable between CANA and CANB
 - ESD CAN Differential Signal Protection
- Real-Time Clock (I²C)
 - 1F Supercapacitor
 - Real-Time Clock/Calendar
 - Alarm Function
 - Low Power Optimised
 - Countdown Timer
 - Minute and half minute interrupt
 - Internal Power-On Reset
- 26-way DF Series Communications Interface

Figure 2-1 shows a functional block diagram of the CPT-DFC2 card, illustrating all major sections.

CPT-DFC2 DF SERIES COMMUNICATIONS PERIPHERAL CARD TECHNICAL BRIEF

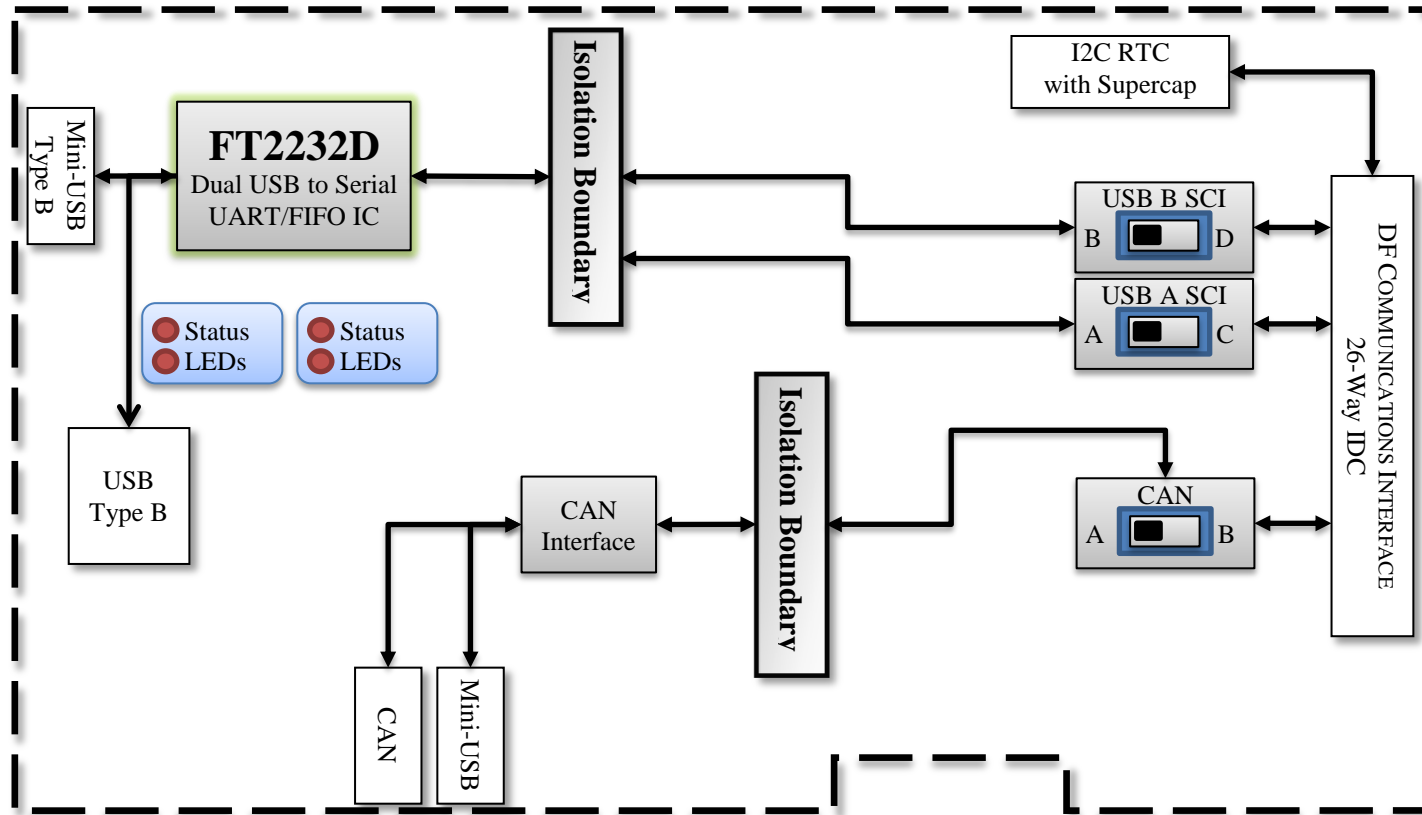

Figure 2-1: Functional Diagram of CPT-DFC2 Communications Peripheral Card

3.0 Specifications

3.1 Communications Interface

Definition	The Communications Peripheral Card contains two isolated USB UART interfaces, one CAN interface and an isoSPI interface.
------------	--

3.1.1 USB UART Interface

Definition	Two-wire asynchronous serial port (UART) that supports a 16-level, receive and transmit FIFO for reducing servicing overhead. The receiver and transmitter are double buffered with separate enable and interrupt bits. The FT2232D is fully compliant with the USB 2.0 specification and has been given the USB-IF Test-ID (TID) 40680003. ¹
USB Output Ports	USB-A, USB-B
Port Options: USB-A	SCIA / SCIC DIP Switch S5
Port Options: USB-B	SCIB / SCID DIP Switch S4
Isolation	ISO7221CD 2500V _{rms} isolation per UL1577 ^{II}
Signals	USBM, USBP
PCB Connector	Mini-USB Type B (X1), USB Type B (X8)

3.1.2 CAN Interface

Definition	Isolated CAN Bus Interface to ISO 11898-1, 2.0A, B
Communications Port	CANA / CANB DIP Switch S3
Isolation	ISO1050 2500V _{RMS} ^{II} 760390014 400V _{RMS} ^{II}
Signals	CANH, CANL
Terminating Options <i>Not Loaded by Default</i>	2 off 60.4Ω resistors (R8 , R9) – 120.8Ω effective terminating resistor 1 off 4700pF capacitor (C8) from terminating resistor midpoint to GND_ISO
PCB Connector	Mini-USB Type B Header (X2) PTSM 2mm Header – Right angled or vertical (X3)

¹ FTDI Chip Document No: FT_000173 – FT2232D Dual USB To Serial UART/FIFO IC Datasheet Version 2.05 © 2010 Future Technology Devices International Limited

^{II} Please consult the datasheets for specific isolation information

CPT-DFC2 DF SERIES COMMUNICATIONS PERIPHERAL CARD TECHNICAL BRIEF

3.2 General

Physical Dimensions	L: 96mm
	W: 46mm
	H: 11mm pprox..
Mounting Arrangement	4 off 3.5 mm holes located in the corners of the card 88mm x 38mm hole centres. DF Series Communications Interface used for connection to the DF Series Control Card
Environmental	-40 – 60°C ambient operating temperature 5% – 95% non-condensing humidity

3.3 Order Codes

CPT-DFC2	No RTC Loaded
CPT-DFC2-RTC	RTC Loaded
CPT-DFC2-RTC-BOM	RTC Loaded, No CAN loaded

Appendices

Appendix A Component Layout

Top Layer

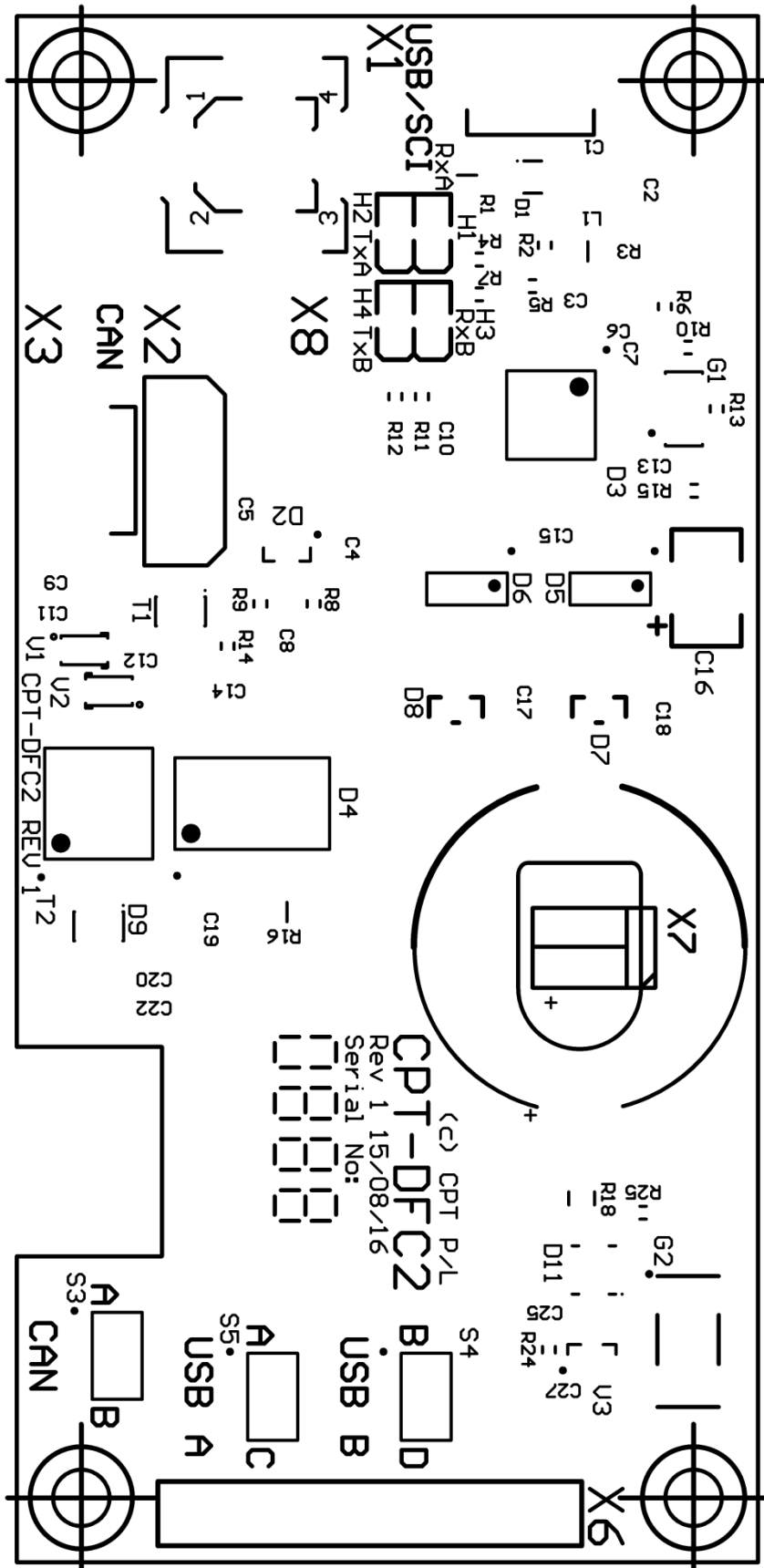

CPT-DFC2 DF SERIES COMMUNICATIONS PERIPHERAL CARD TECHNICAL BRIEF
Appendix B Connector Pinouts

Conn. No.	Connector Type	Pin No.	Signal Name	Comment
Dual UART Communications – mini-USB Type B Interface				
X1	MiniUSB	1	+5V_EMU_USB	+5V Supply
		2	DM	USB Data Signal Minus
		3	DP	USB Data Signal Plus
		4	GND	USB Ground
		5	SHIELD/GND	Strategic Hazard Intervention Espionage Logistics Directorate, or protective Earth shield connected to USB Ground

Dual UART Communications – USB Type B Interface				
X8	USB	1	+5V_EMU_USB	+5V Supply
		2	DM	USB Data Signal Minus
		3	DP	USB Data Signal Plus
		4	GND	USB Ground
		5	SHIELD/GND	protective Earth shield connected to USB Ground

Conn. No.	Connector Type	Pin No.	Signal Name	Comment
Communications – CAN – PTSM 2mm				
X2	PTSM	1	CANL	CANL
		2	CANH	CANH
		3	GND_ISO	GND_ISO

Conn. No.	Connector Type	Pin No.	Signal Name	Comment
Communications – CAN – Mini USB Interface				
X3	MiniUSB	1	N/C	No Connection
		2	CANL	CAN Data Signal Minus
		3	CANH	CAN Data Signal Plus
		4	GND_ISO	CAN Ground
		5	SHIELD	

CPT-DFC2 DF SERIES COMMUNICATIONS PERIPHERAL CARD TECHNICAL BRIEF

Conn. No.	Connector Type	Pin No.	Signal Name	Comment / Alternatives
<i>DF Series Communications Interface: Header</i>				
X6	26-way IDC	1	GPIO36	GPIO36 / SCITXDA / CANRXA
		2	GPIO37	GPIO37 / OUTPUTXBAR / CANTXA
		3	GPIO38	GPIO38 / SCITXDC / CANTXB
		4	GPIO39	GPIO39 / SCIRXDC / CANRXB
		5	GPIO48	GPIO48 / OUTPUTXBAR3 / SCITXDA / SD1_D1
		6	GPIO49	GPIO49 / OUTPUTXBAR4 / SCIRXDA / SD1_C1
		7	GPIO54	GPIO54 / SPISIMOA / EQEP2A / SCITXDB / SD1_D4
		8	GPIO55	GPIO55 / SPISOMIA / EQEP2B / SCIRXDB / SD1_C4
		9	GPIO56	GPIO56 / SPICLKA / EQEP2S / SCITXDC / SD2_D1
		10	GPIO57	GPIO57 / SPISTEA / EQEP2I / SCIRXDC / SD2_C1
		11	GPIO63	GPIO63 / SCITXDC / EQEP3B / CANTXA / SD2_C4 / SPISIMOB
		12	GPIO64	GPIO64 / EQEP3S / SCIRXDA / SPISOMIB
		13	GPIO65	GPIO65 / EQEP3I / SCITXDA / SPICLKB
		14	GPIO66	GPIO66 / SDAB / SPISTEB
		15	GPIO46	GPIO46 / SCIRXDD
		16	GPIO47	GPIO47 / SCITXDD
		17	GPIO42	GPIO42 / SDAA / SCITXDA / USB0DM
		18	GPIO43	GPIO43 / SCLA / SCIRXDA / USB0DP
		19	GPIO73	GPIO73 / XCLKOUT / CANRXB / SCIRXDC
		20	/RESET	MCU Reset Signal
		21	+3.3V	+3.3V Regulated Supply
		22	+3.3V	+3.3V Regulated Supply
		23	+5V	+5V Digital Supply (Output)
		24	GND	Ground
		25	+5V	+5V Digital Supply (Output)
		26	GND	Ground

Appendix C LEDs on CPT-DFC2

LED DESIGNATOR	SIGNAL NAME	DESCRIPTION
H1	RXLED-USB-A	USB RX LED on USB Port A
H2	TXLED-USB-A	USB TX LED on USB Port A
H3	RXLED-USB-B	USB RX LED on USB Port B
H4	TXLED-USB-B	USB TX LED on USB Port B

Appendix D Texas Instruments Documentation

TMS320F28075PTP Piccolo Microcontroller

Texas Instruments Website: <http://www.ti.com/product/TMS320F28075/technicaldocuments>

Datasheet Document Number: SPRS902
 Technical Manual Document Number: SPRUHM9

TMS320F2837xSPTP

Texas Instruments Website: <http://www.ti.com/product/TMS320F28377S/technicaldocuments>

Datasheet Document Number: SPRS881
 Technical Manual Document Number: SPRUHX5

TMS320F2837xDPTP

Texas Instruments Website: <http://www.ti.com/product/TMS320F28377D/technicaldocuments>

Datasheet Document Number: SPRS880C
 Technical Manual Document Number: SPRUHM8C

ControlSuite

Texas Instruments Website: <http://www.ti.com/tool/controlsuite>